

H. MELLISH.
Machines for Cutting Clothes-Pins.
No. 152,569. Patented June 30, 1874.

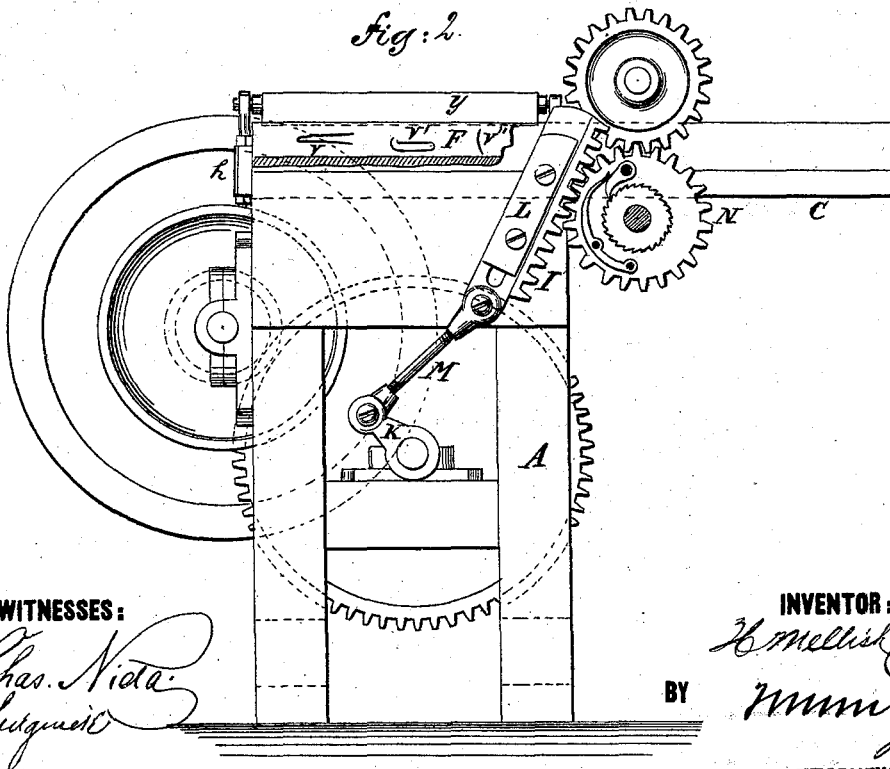
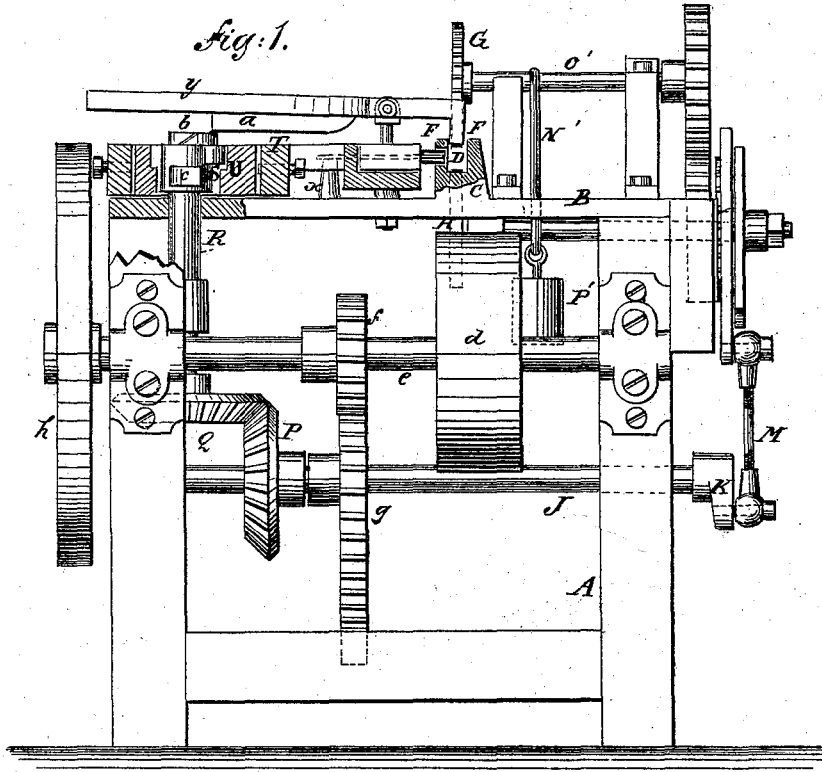

WITNESSES:
Chas. N. ...
...

INVENTOR:
H. Mellish
BY *...*
ATTORNEYS.

H. MELLISH.

Machines for Cutting Clothes-Pins.

No. 152,569.

Patented June 30, 1874.

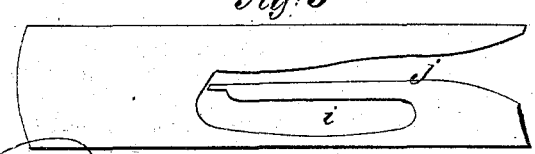
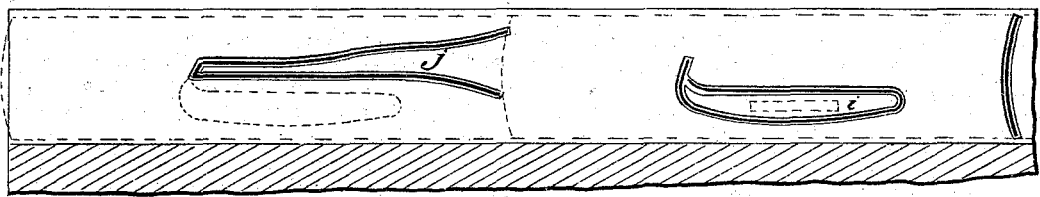
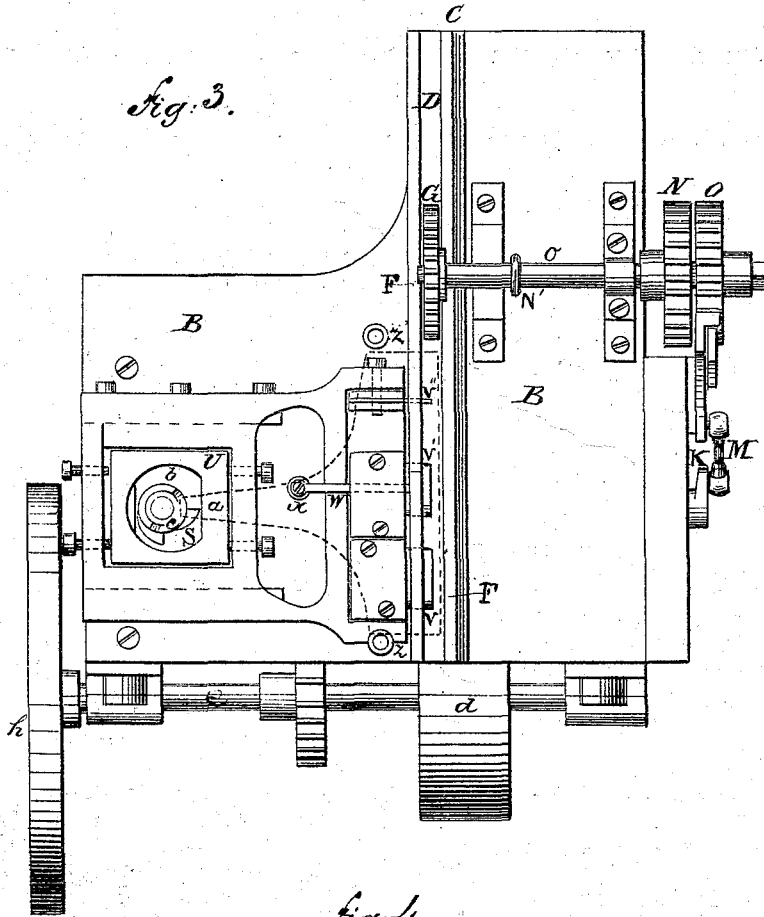

WITNESSES:

Chas. Nida
Admiral

INVENTOR:

H. Mellish

BY

Munnell

ATTORNEYS.

UNITED STATES PATENT OFFICE.

HENRY MELLISH, OF WALPOLE, NEW HAMPSHIRE, ASSIGNOR TO WYMAN FLINT AND GEORGE H. MELLISH, OF BELLOWS FALLS, VERMONT.

IMPROVEMENT IN MACHINES FOR CUTTING CLOTHES-PINS.

Specification forming part of Letters Patent No. **152,569**, dated June 30, 1874; application filed April 4, 1874.

To all whom it may concern:

Be it known that I, HENRY MELLISH, of Walpole, in the county of Cheshire and State of New Hampshire, have invented a new and useful Improvement in Machine for Cutting Clothes-Pins, of which the following is a specification:

The object of this invention is to rapidly cut bifurcated clothes-pins of any kind, but more especially the kind described in Letters Patent granted me, dated September 23, 1873, No. 143,024, by the combination, in a machine for cutting clothes-pins, of stationary channel or groove, in which to alternately move and hold the timber, by means of feed-wheels and a holding-plate, while the pins are being cut, and the machinery hereinafter described.

The ordinary bifurcated clothes-pins (now in common use) are very liable to split and be destroyed, and to work from the line when the clothes are agitated by the wind. Such pins are cheap if the first cost only is considered, but dear if the consequences of this use are considered.

In the accompanying drawing, Figure 1 is a side elevation of the machine. Fig. 2 is an end elevation, showing the feeding mechanism. Fig. 3, Sheet 2, is a top or plan view. Fig. 4 is a view of the piece of timber from which the pins are cut, showing the action of the cutters in the process of forming the pin. Fig. 5 is a side view of the pin complete.

Similar letters of reference indicate corresponding parts.

A is the frame, of rectangular form, which supports the operating parts of the machine. B is a metallic plate, firmly attached to the frame. C is a bar, (either cast with the plate or attached thereto,) having a deep channel or groove, D, through which the piece of wood is fed, and in which the pins are cut. The cutters work through one of the flanges F F of the groove, and the piece is drawn through by a feed-wheel, G, above, and another wheel, H, below the groove, the latter working through the bottom of the groove, as seen in Fig. 1. These feed-wheels receive an alternating motion from the mechanism seen in Fig. 2, by which the piece of wood is moved to the proper position, and remains at rest while the

cutters are at work. I is a rack, attached to the shaft J by the crank K. (See Figs. 1 and 2.) This rack slides on the guide-plate L. An alternating motion of the feed-wheel is produced by means of a small ratchet-wheel attached to the inner wheel, N, (see Fig. 3,) and a spring-pawl attached to the inside of the outer wheel, O, as seen in Fig. 2. The spring-pawl is shown on the inner wheel, N, but it is attached to the outer wheel, O. The rack I works in the outer wheel, O, and the ratchet and pawl are so arranged that the two wheels engage only when the rack is moving downward, which moves the wheels G and H, to give the feed. When the rack is ascending, the pawl slips over the ratchet-wheel, and the wheel N (and consequently the feed-wheels) remains at rest. N' is a hook on the shaft O', to which is attached a weight, P', to cause sufficient friction to move the timber forward.

In Fig. 2 the groove-bar C is shown partly in section, the apertures in the flange F (through which the cutters work) being shown.

The horizontal shaft J extends through the frame, and, by means of the bevel-wheels P and Q, actuates the vertical shaft R. On this shaft R is an eccentric, S. T is a sliding plate or carriage, which carries the cutters, and is given a horizontal movement on guides attached to the top plate B by the eccentric S. U is the eccentric box, which is secured in the plate T by set-screws. V V' V'' are the cutters, V'' being the cut-off cutter. These cutters are confined in a recess in the plate T, and work through the flange F into the groove D, and penetrate the wood to a depth equal to the throw of the eccentric or the movement of the carriage T. This movement may be equal to the thickness of the wood, so as to cut entirely through.

I prefer to have the timber sufficiently thick for two clothes-pins when it is fed in, and to have the cutters penetrate half-way from each side, (two machines being used,) and then to split the timber with a buzz-saw and separate the pins. The machine may be made double, (or with two sets of cutters;) but I prefer to use two machines.

W is a stationary bar or piston, attached to the post X, for one or both of the hollow cut-

ters $V V'$, the end of which bears against the wood, to prevent the withdrawal (by the cutter) of the chip cut. Y is a holding-plate, which is pivoted to the stands $Z Z$ on the top plate B of the machine. An edge view of this plate is seen in Fig. 1, and a top view (in dotted lines) is seen in Fig. 3. On the under side of this plate is a rib, a . b is a cam on the top of the vertical shaft R .

When the feed ceases and the piece of wood is stationary and the cutters ready to work, this plate is tipped by the cam b , which strikes the rib a and raises the plate, so that its other end presses on the wood in the groove and holds it down, to prevent splitting while it is being cut. This cam is so formed and arranged that the pressure is continued while the cutters are at work, and discontinued when they are withdrawn.

The back motion of the cutter-plate T is produced by the cam c on shaft R below the eccentric. d is the driving-pulley on the shaft e . The feed-shaft J is revolved by means of the two spur-wheels $f g$. h is a fly-wheel on the driving-shaft e .

The timber is, preferably, softened by steaming, and the pieces are four feet (more or less) in length.

For making the openings i and j , the cutters penetrate half-way through the piece as the lathe is passed through this machine, as before stated. The next machine cuts the other side in the same manner, and then the piece of wood is split, which separates and completes the pins. The cutter V'' cuts into the piece to give the length of the pin. The cuts in the two sides of the piece are not opposite each

other, so that the piece holds together until it is split to separate the pins.

The pin itself is secured to me by a separate patent, as before stated.

Having thus described my invention, I claim as new and desire to secure by Letters Patent—

1. In a machine for cutting clothes-pins, the stationary lumber guide or channel D , arranged in relation to cutters operating horizontally through the side wall of said channel, substantially as herein described.

2. In combination with a tubular or hollow cutter, V , operating as described, the stationary bar or piston W , extending through said cutter, for the object stated.

3. The combination of the channel or groove D , cutters V , V' , and V'' , stationary piston W , sliding carriage T , and feed-wheels G and H , substantially as and for the purposes described.

4. In a machine for cutting clothes-pins, the combination of intermittently-acting cutters with revolving feed-wheels, held inactive when the cutters are in operation, substantially as herein shown and described.

5. In a machine for cutting clothes-pins, the hinged or movable presser-plate Y , combined with the reciprocating cutter-carriage, and operating to bear upon the lumber during the cutting operation, substantially as herein described.

HENRY MELLISH.

In presence of—

CHAS. B. MELLISH,
W. S. MYERS.